

# Agilent BioTek Imaging and Microscopy

Ready for any assay

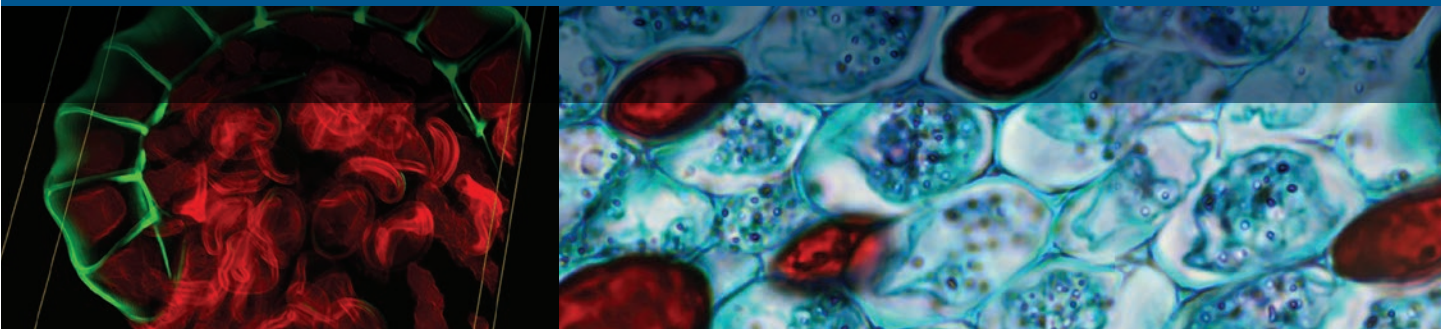

# Agilent BioTek Imaging and Microscopy



## Designed for a wide range of applications and budgets

Agilent BioTek Lionheart automated microscopes offer powerful microscopy and can easily be equipped with the environmental controls that are crucial for successful short- and long-term kinetic live cell imaging.

The Agilent BioTek Cytation C10 confocal imaging reader combines confocal, widefield and multimode detection in a single benchtop-sized platform, attainable for every laboratory. The Agilent BioTek Cytation cell imaging multimode readers offer an array of imaging and multimode capabilities, including digital widefield inverted microscopy, upright microscopy and environmental controls for live cell workflows.

Agilent BioTek Gen5 microplate reader and imager software includes functionality for easy image capture and analysis, for both qualitative and quantitative data.



Top row: Agilent BioTek Lionheart FX and Lionheart FX automated microscopes  
Bottom row: Cytation C10 confocal imaging reader and Agilent BioTek Cytation 7, 5 and 1 cell imaging multimode readers

## Augmented microscopy

Agilent BioTek instrumentation and software together create the unique Augmented Microscopy experience; the integration and automation of all steps from image capture to publication-ready data. There's no need for other software – Gen5 does it all.

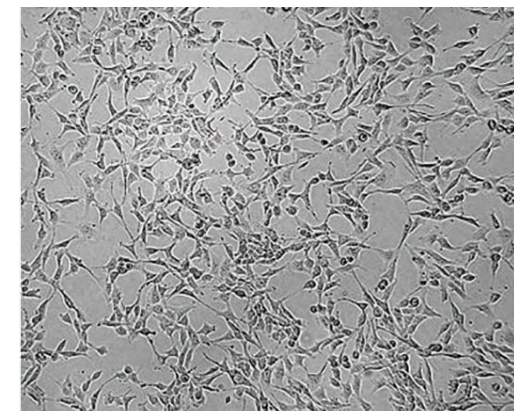

Capture

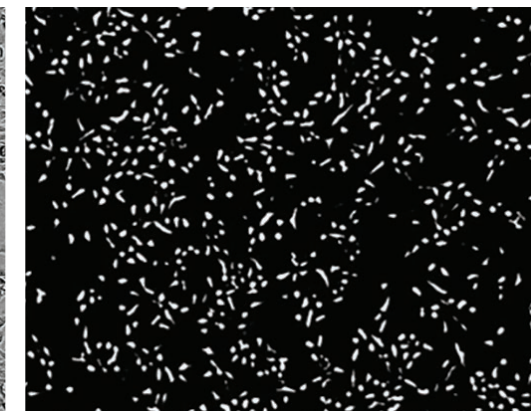

Process

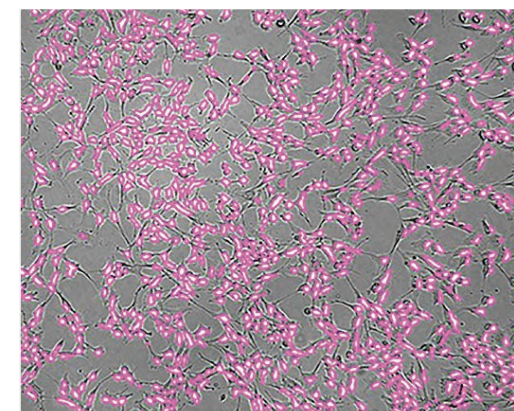

Analyze

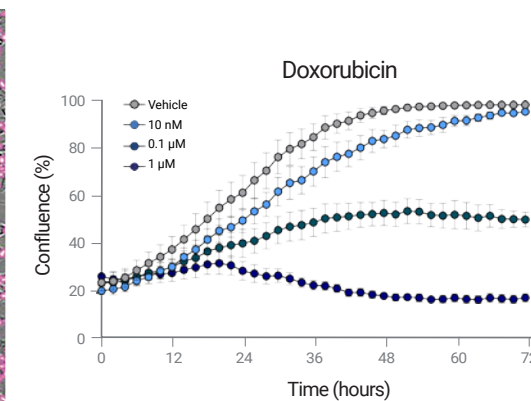

Publish

# Capture



The critical first step in a typical microscopy workflow is the efficient and precise acquisition of publication quality, high-information images. Augmented Microscopy automates image capture for samples with powerful tools for endpoint and time lapse workflows.

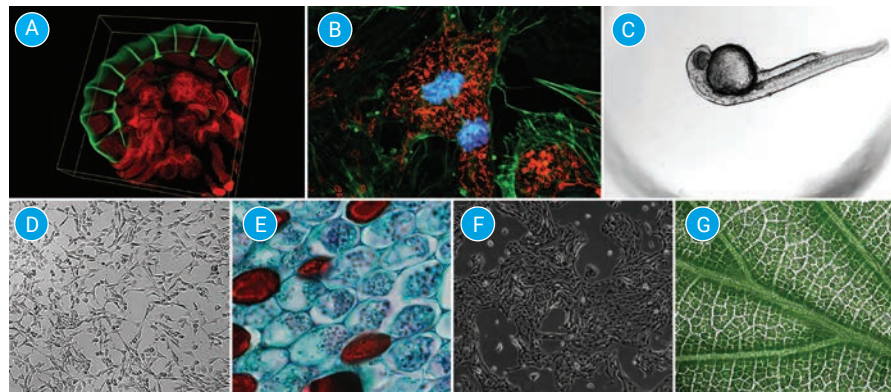

## Seven imaging modes

Powerful imaging for a wide range of applications, including live and fixed cell biologies: **A.** Confocal, **B.** Fluorescence, **C.** Brightfield, **D.** High-contrast brightfield, **E.** Color brightfield, **F.** Phase contrast, **G.** Upright reflected and transmitted light.

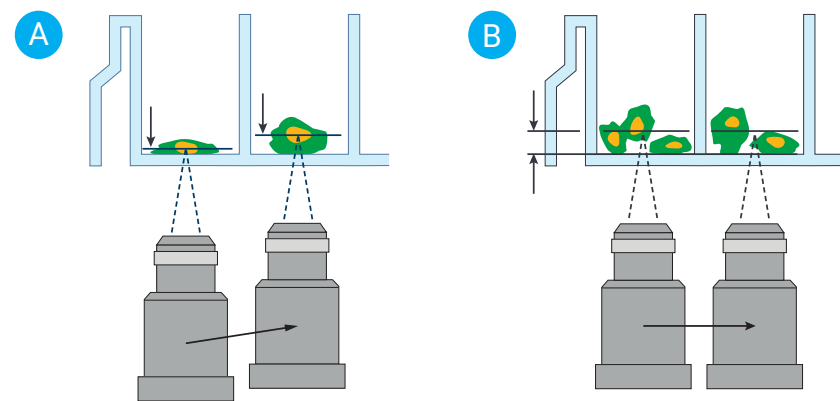

## Laser and image autofocus

**A.** Image-based autofocus is available on all Agilent BioTek imaging systems. It focuses on the plane of highest contrast in the sample, including "shifting" biology within the well.

**B.** BioTek patented laser autofocus uses the same focal offset from well to well and is typically faster. It works with dim fluorophores and helps prevent phototoxicity and photobleaching. Laser autofocus also offers better reproducibility and higher accuracy during long term kinetic.

# Capture

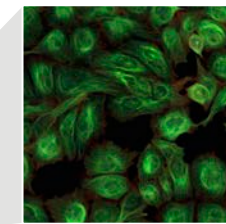
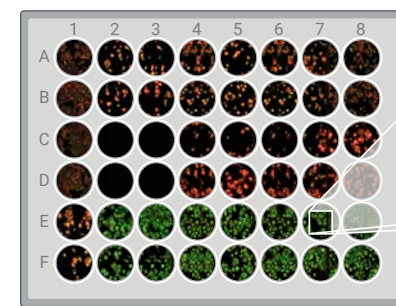

## Batch mode

Capture multiple images in microplates, chamber slides and other multi-sample vessels automatically. Agilent BioTek imagers can be used in manual mode to look at a few samples, or in full automation mode to capture endpoint images or extended kinetics over hours, days or weeks.

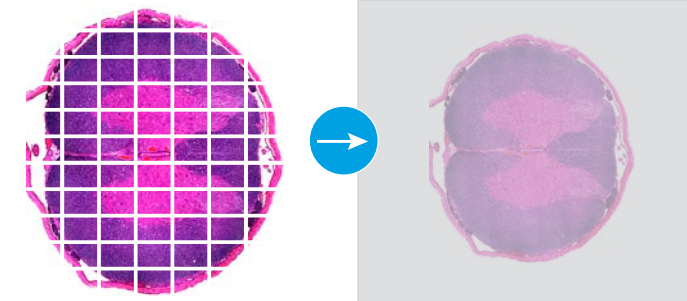

## Montage

Capture large samples, like tissue sections (H&E), increase sample size for better data quality or to detect rare events. Montage image capture mode acquires up to 2000 tiled images per sample.

Each tile of a montage is saved as an individual, high-resolution 16-bit TIFF. Stitching in Gen5 creates a seamless image.

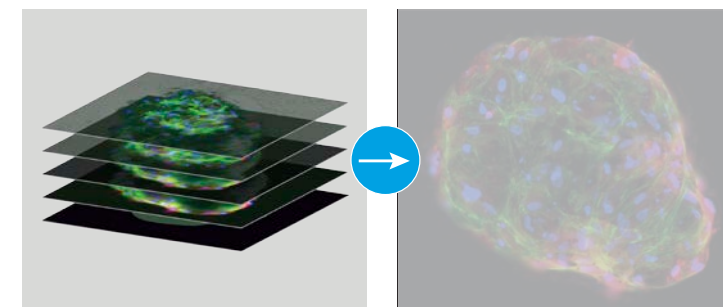

## Z-stack

Z-stacking in Gen5 enables capture of up to 50 customizable slices – as thin as 0.1  $\mu\text{m}$  – in a stack. The images can then be automatically z-projected. Z-stack capability is a critical requirement for imaging 3D samples, such as spheroids and tumoroids, along with samples that extend over multiple focal planes.

# Capture

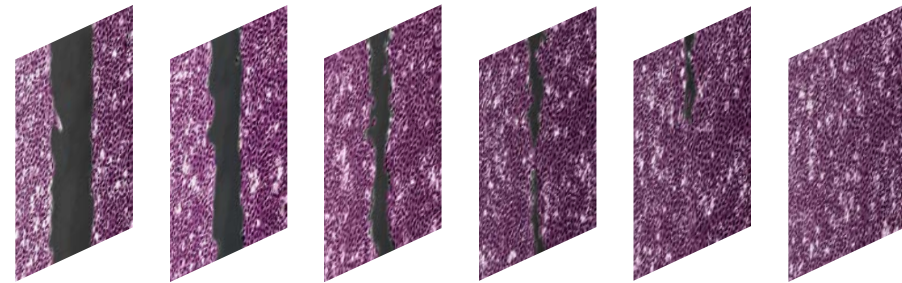

## Time-lapse imaging

**Time: days to weeks**

Live cell kinetic assays such as wound healing and cell proliferation are imaged automatically over time, stored and ready to be published as a movie. Experiments can be run over days or weeks, and kinetic data is automatically plotted.

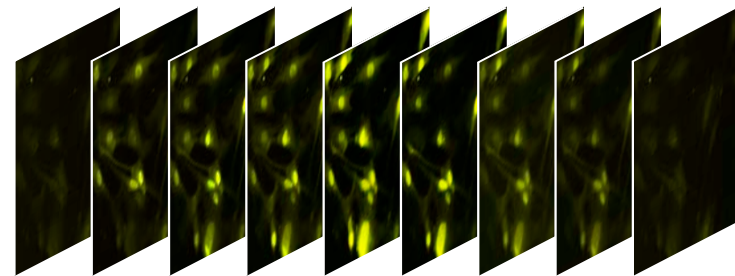

## High-speed imaging

**Time: seconds to hours**

Very fast reactions like calcium flux kinetics are enabled with dual reagent injectors – images are automatically captured at up to 20 frames per second.

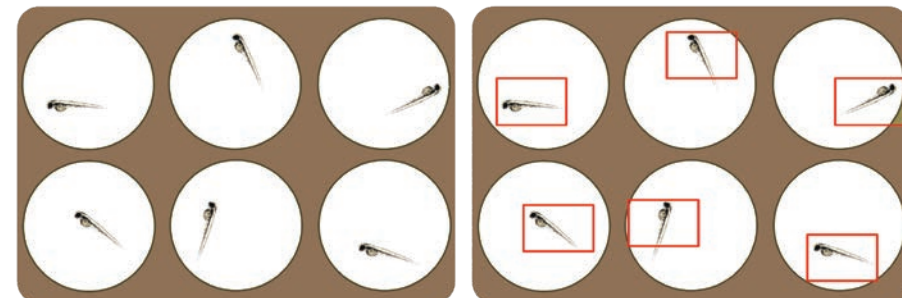

## Beacons

Beacons are used to define custom x/y offsets for imaging in a well or vessel. Beacons are useful for monitoring specific regions of interests, as shown in this zebrafish example.

# Capture



## Live cell assay support

Temperature control, including the Condensation Control gradient, plus CO<sub>2</sub>/O<sub>2</sub> control and humidity options provide the ideal environment for live cell assays. Observe label-free assays with brightfield and high-contrast brightfield imaging, or fluorescence assays in up to 4 colors plus brightfield. Image time lapse sequences are easily, automatically compiled to video.

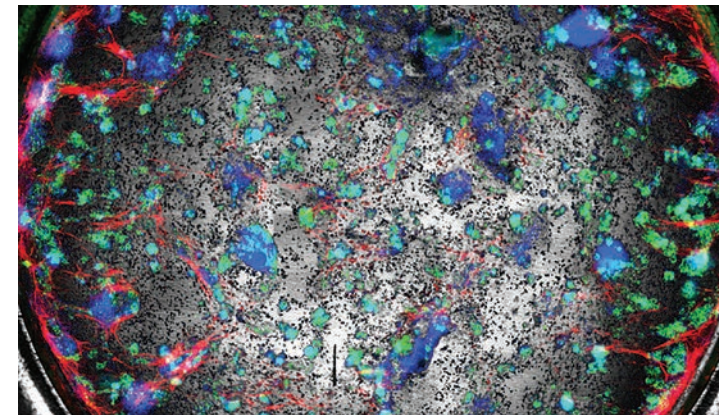

## Up to four channel overlay

Four fluorescence channels plus brightfield provide maximum versatility. Choose from nearly 20 available LED/filter cube colors to cover a very broad range of fluorescent stains. Auto LED intensity ensures consistent capture for end point and kinetic sequences. Each channel can be automatically adjusted and optimized – changes are easily saved.

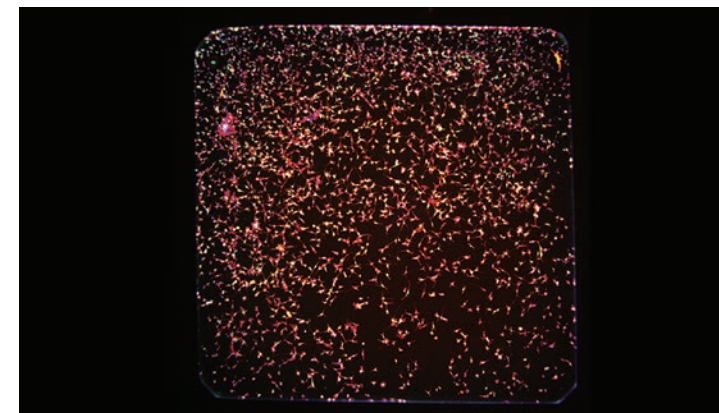

## Whole well imaging

The wide field of view (wide FOV) camera available on the Cytation platform enables capture of an entire well of a 384-well plate in a single image. High-resolution cellular screens can be captured much more rapidly, since multiple images aren't required. The wide FOV camera captures more cells in the field of view at higher magnification, providing a more statistically relevant population of cells in fewer images.

# Process



# Process

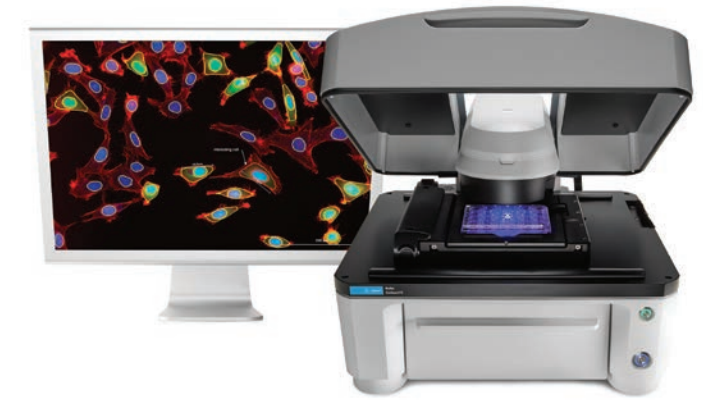

Lionheart FX automated microscope

Image processing is essential for optimizing images prior to analysis. Processing tools in Gen5 provide exceptional processing capability to facilitate the analysis of complex biologies.

## Powerful review tools



Cytation 7 shown with CO<sub>2</sub>/O<sub>2</sub> gas Controller and dual reagent injector.

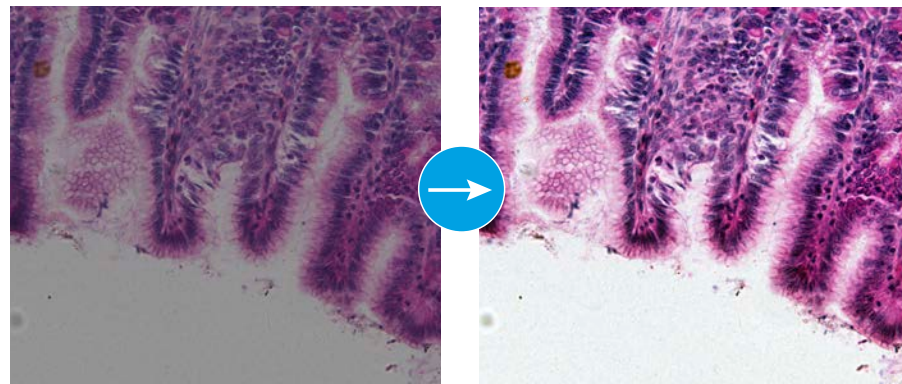

Quickly adjust brightness and contrast for better visualization. Measurement and annotation tools allow you to add information or highlight specific areas and objects of interest in the image.

## Background flattening

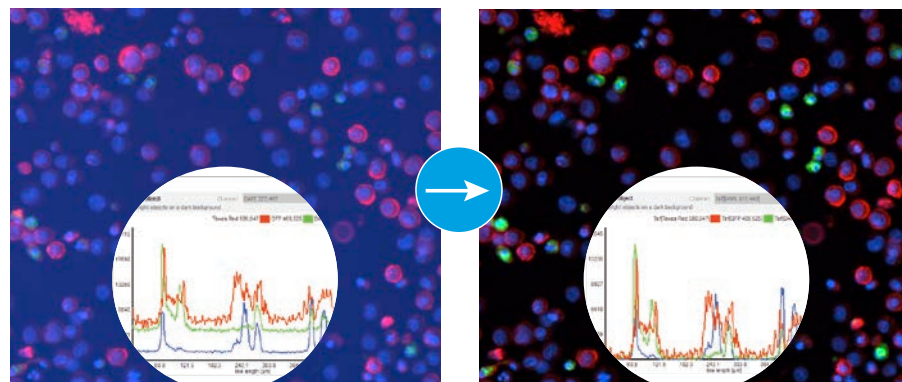

Background flattening using a rolling ball algorithm prepares the image for analysis by removing background artifacts and correcting for uneven illumination. Use the line profile tool to find recommended threshold values for image analysis.

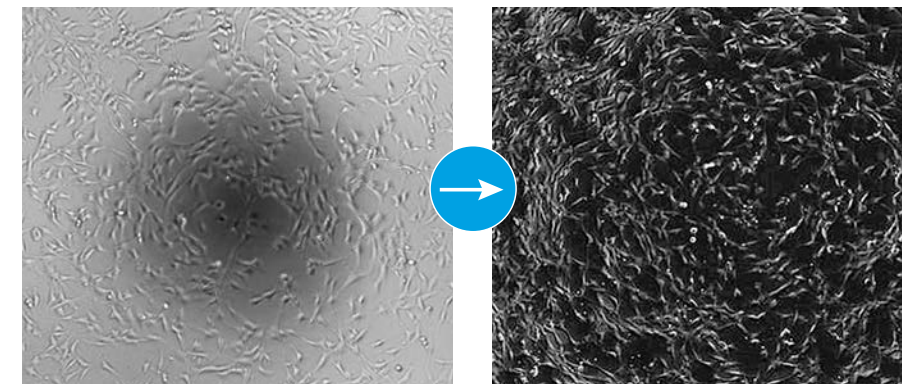

## Digital phase contrast

Digital phase contrast improves brightfield contrast to correct for meniscus effect and other artifacts. The process enables clear visualization and easier analysis.

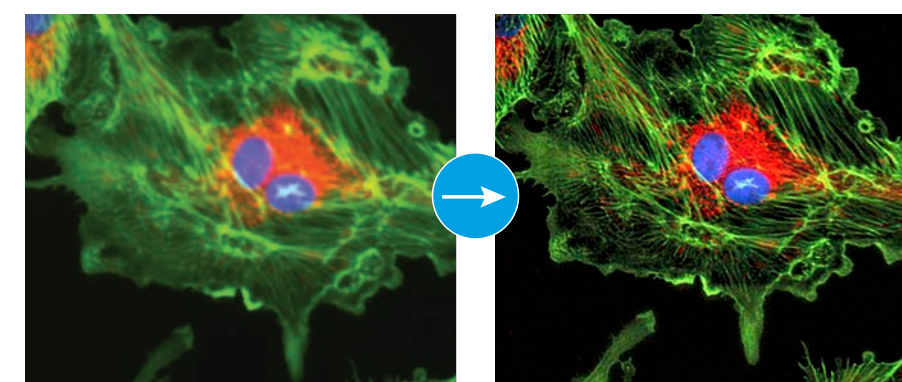

## Deconvolution

Deconvolution reduces blur from out-of-focus light, commonly seen in widefield imaging. It improves image resolution, enabling better visualization of image details.

# Process



## Stitching

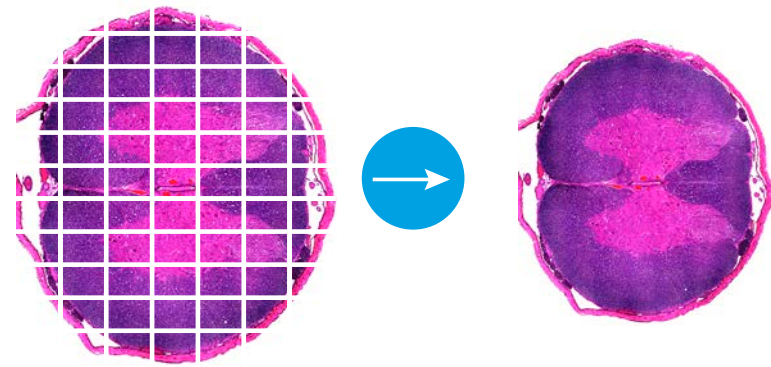

After capturing a large field of view with an image montage, Gen5 automatically and precisely stitches the montage into a single uniform, high-resolution image. Gen5 can correct common artifacts seen with some montages, such as tiling effects. The stitching process automatically adjusts and corrects for a seamless image.

## Z-projection with 3D rendering

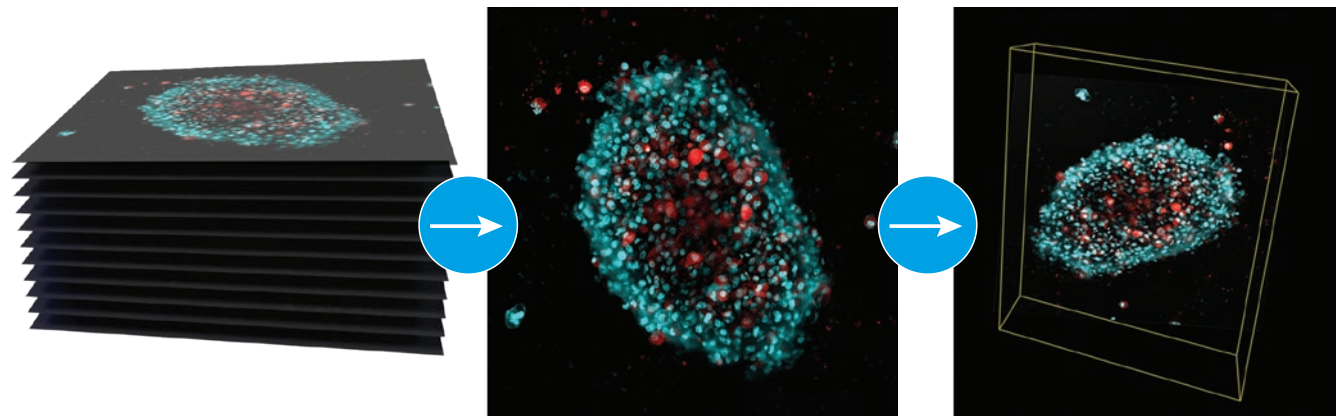

A z-stack is captured, then Gen5 processes the stack of images into the spheroid. The 3D viewer is used to explore the sample in greater detail.

## Process

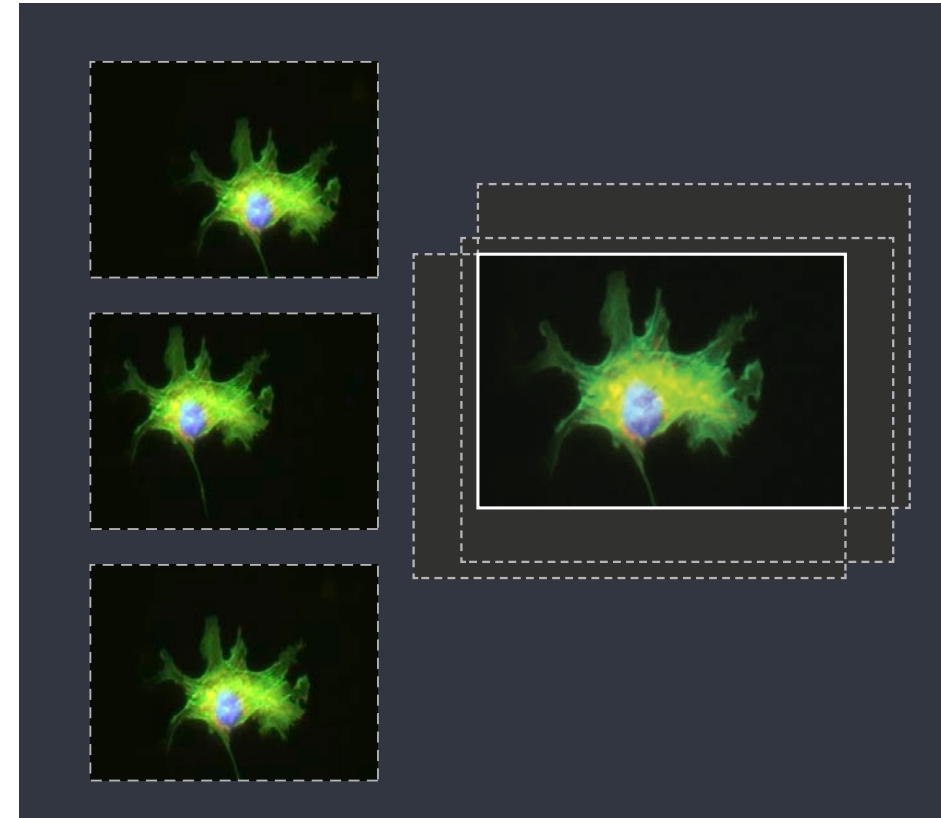

## Kinetic image alignment

During live cell kinetic imaging, samples can sometimes shift slightly. Gen5 automatically adjusts for positional differences, keeping the region of interest fully stabilized, even during long-term imaging.

## Movie file creation

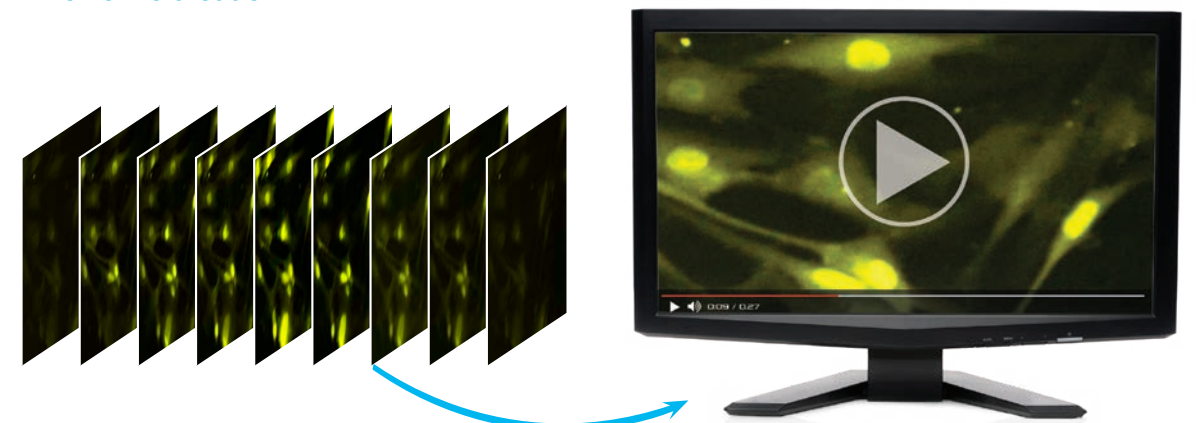

Gen5 quickly compiles time lapse images into time-stamped .wmv or .mp4 files.

# Analyze



Captured, processed images are ready for analysis. Image analysis tools in Gen5 cover a very broad range of application requirements, and are both powerful and easy to use. Analysis functions in Gen5 extend to quantitative data as well.

## Confluence

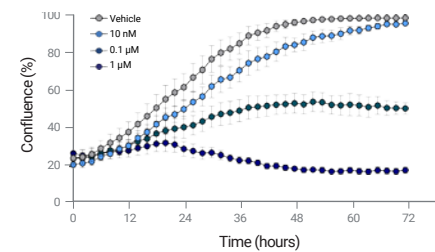
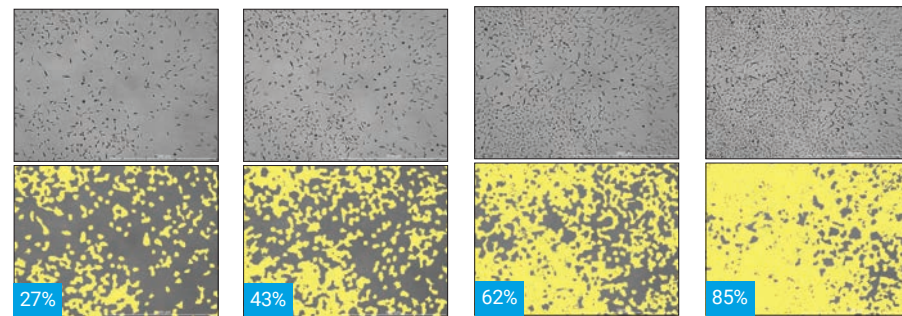

Confluence measurements quickly and accurately identify and mask cells. In cell growth, health and proliferation studies, % confluence is an important measurement.

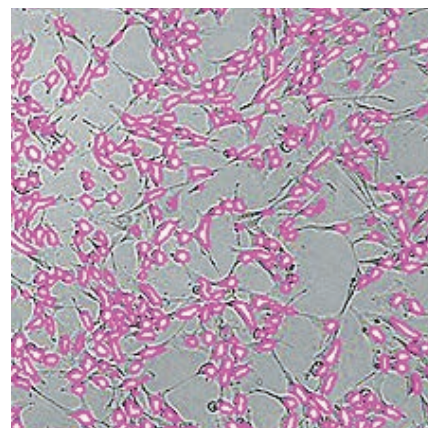

## Label-free cell count

Fluorescent stains can sometimes interfere with cellular functions, so label-free methods are increasingly being used for cell counting.

Along with label-free confluence measurements, label-free cell counts are performed efficiently using high-contrast brightfield. Cell counts are essential to cell growth, health and proliferation studies. Gen5 efficiently identifies highly confluent cells without dyes.

# Analyze

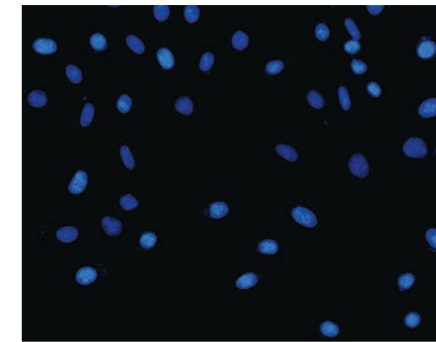

Original image

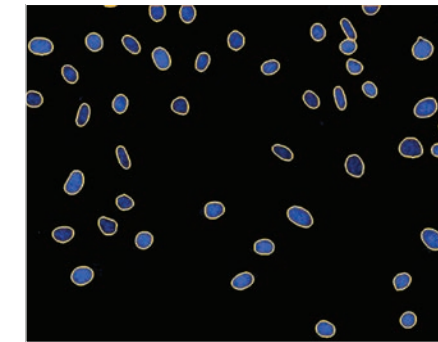
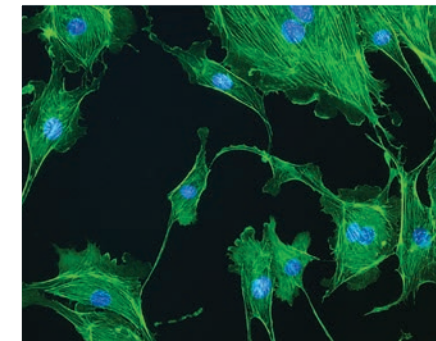

Image with mask applied

## Nuclei count and analysis

Gen5 automatically identifies cell nuclei for rapid cell counts. Applications include cell proliferation, cell cycle and toxicity analysis. This primary mask can also be used to count non-mammalian cells, spores and bacteria.



Original image

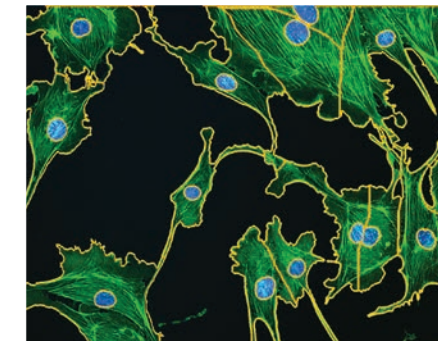

Image with mask applied

## Cytoplasm analysis

A secondary mask enables observation and characterization of cytoplasm size, shape, intensity, and other morphological changes, which are common to a broad range of applications.

## Organelle analysis

The add-on spot count module for Gen5 enables in-depth analysis of intracellular objects of interests ("spots"), within either a primary or secondary mask. Measurements include spot count, average spot size and area, total spot area per cell, mean, standard deviation and integral spot intensity. The module is a useful tool for applications including analysis of steatosis, autophagosomes, liposomes, micronuclei, viral infections and many assays with punctate biology.

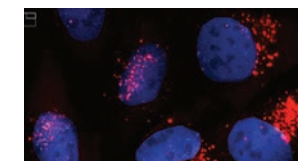

Nuclei and objects for counting

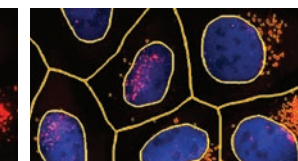

Spot counting of objects within primary and secondary masks

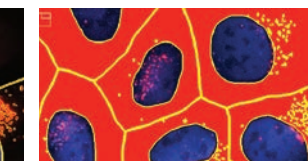

Spot counting with secondary mask filled for better visualization

Cell migration/scratch wound assays

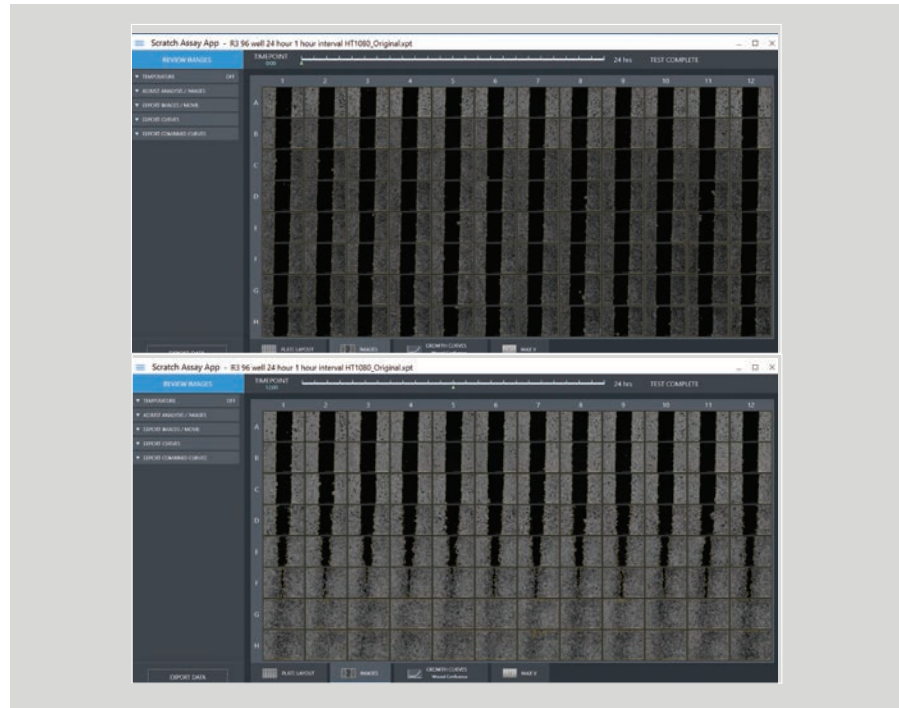

Cell migration and invasion assays such as scratch wound healing are kinetic processes easily handled in Gen5 software. Migration analyses and measurements include wound width, % confluence, maximum healing rate (max V) and spheroid size.

The Agilent BioTek AutoScratch wound making tool automates the implementation of automated scratch wound assays. (See Automation Accessories on page 26)



Cytation C10 shown with CO<sub>2</sub>/O<sub>2</sub> gas controller and dual reagent injector.

Signal translocation

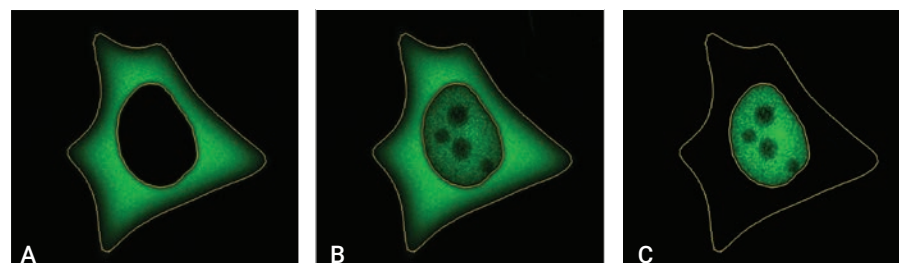

Monitoring molecular movement between cellular compartments, typically referred to as translocation, requires advanced cell analysis tools. This response is seen in many assays, including transcription factor activation and caspase cascade events (apoptosis), as shown. Using a nuclear mask and a cytoplasmic mask, Gen5 automatically quantitates translocation events.

- A.** Protein (caspase-3) in a resting state stays within the cytoplasm
- B.** Upon activation, caspase-3 begins translocating to the nucleus
- C.** Caspase-3 has completely translocated, eliciting the desired cellular effect, such as apoptosis

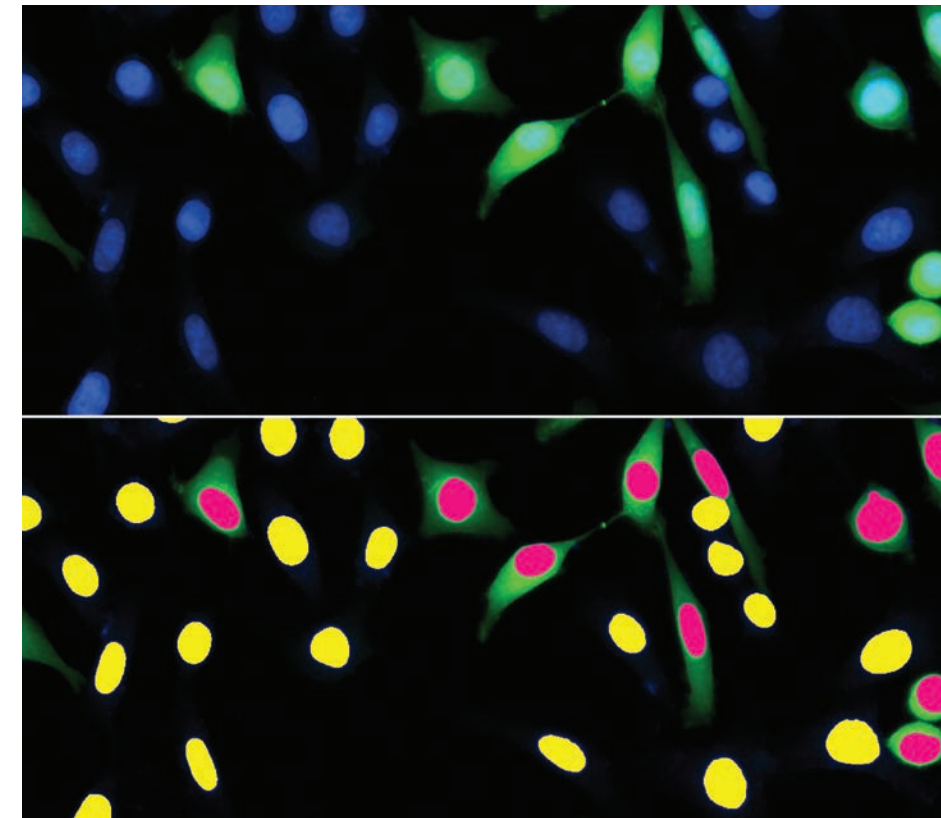

Subpopulation analysis

Cell populations rarely have homogenous responses. Subpopulation analysis is a powerful tool to identify various response levels or outliers within the population. Typical applications include rare event detection, transfection efficiency calculation, viral infection, among many others.

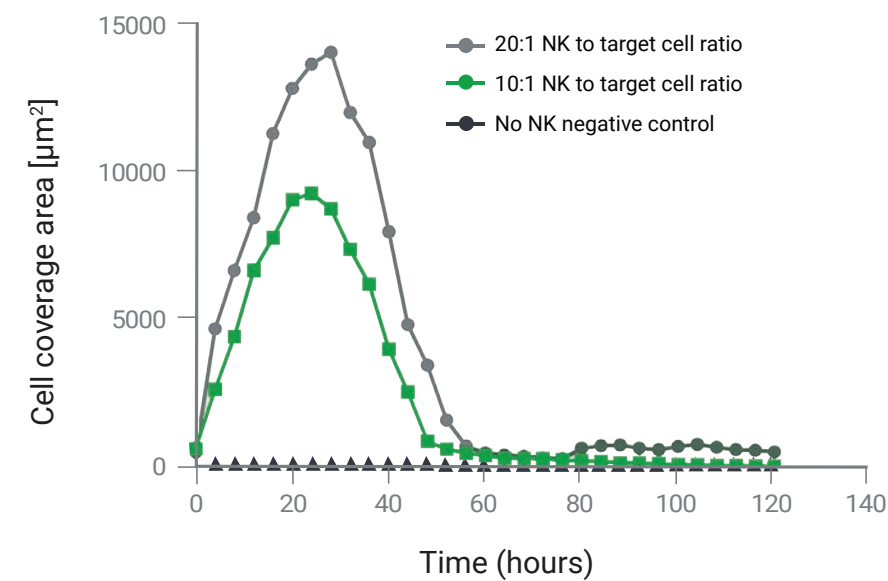

Kinetic analysis

Any cellular measurement can be plotted over time to better visualize real-time cellular dynamics. Kinetic calculations include rate of change, min/max signal, lag time, peak response.



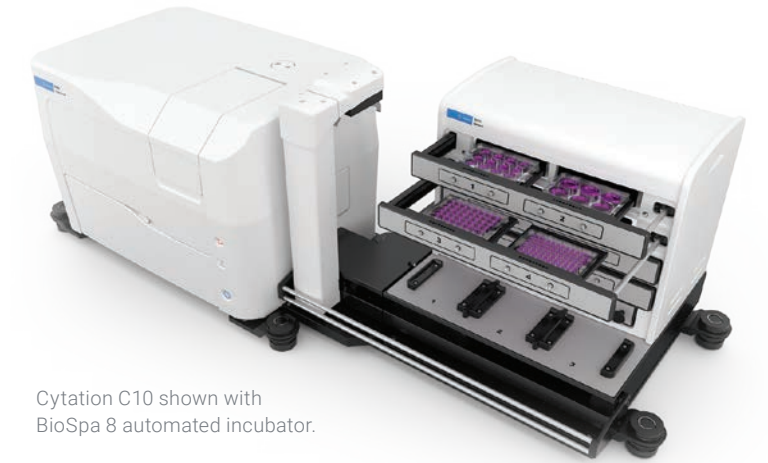

Cytation C10 shown with BioSpa 8 automated incubator.

Augmented Microscopy tools include the ability to create publication-ready images, graphs and data using the functions in Gen5 software. There is no need to export images or data to external software.

### Scatter plots and histograms

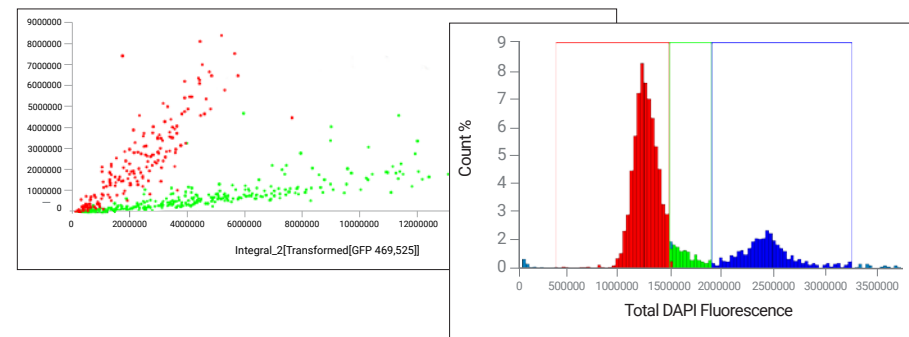

Commonly used in flow cytometry, scatter plots are a powerful tool to visualize variations within large cell populations. This scatter plot shows two distinct populations, responders are in red, normal population is in green. The histogram shows subpopulations of object total DAPI fluorescence.

### Image and graph annotations

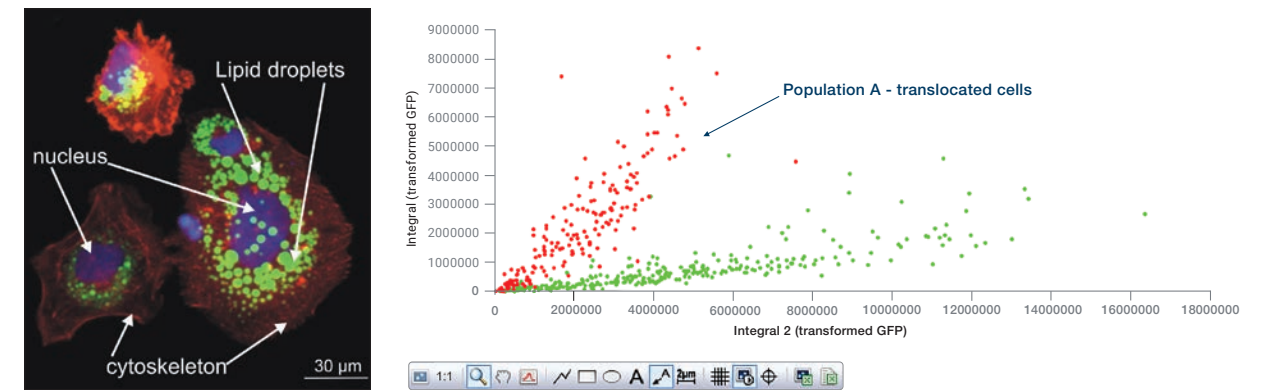

Use the annotation tools in Gen5 to highlight important elements of an image or graph. Add text, measurement lines, callouts, shapes and grids to an image – they are saved along with the image or video, ready for publication.

### Data analysis

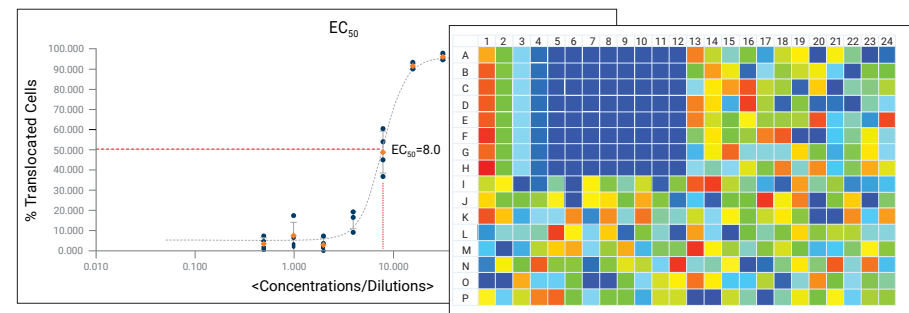

Gen5 includes data analysis tools that are often handled in third party software, enabling a complete workflow within one platform. Powerful analyses such as  $EC_{50}$ , parallel line analysis, statistical analysis, heat maps and custom calculations are all built-in to Gen5.

### Raw image retention

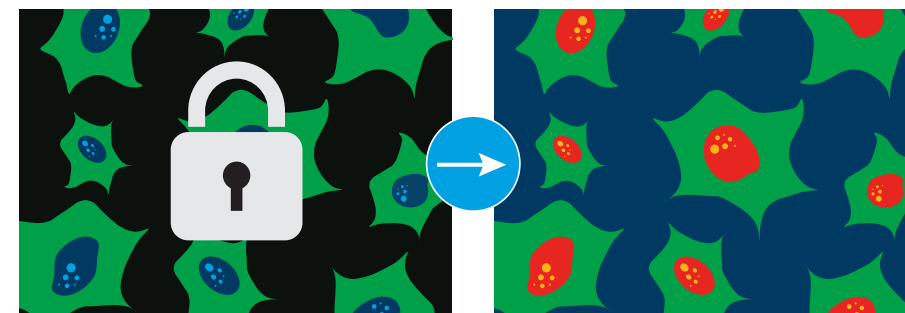

Before processing or analyzing images, Gen5 makes a copy of the raw data and the raw data is retained as a separate file. Gen5 protects raw images and provides traceability from the raw through the modified images.

# Select Applications



Agilent BioTek imaging and microscopy instruments, along with Gen5 software, are capable of automating a broad range of application workflows. Augmented Microscopy tools guide users through the four major steps of microscopy: capture process analyze publish across a broad range of applications. In this section are just a few examples of important applications easily managed with Agilent BioTek imagers and Gen5 software.



Cytation 5 cell imaging multimode reader

# Select Applications

## 3D natural killer (NK) cell cytotoxicity

Cancer cells are suspended in hydrogel and propagate to form 3D tumoroids. NK cells are then introduced and apoptotic and necrotic induction within cancer cells is then measured over 120 hours.

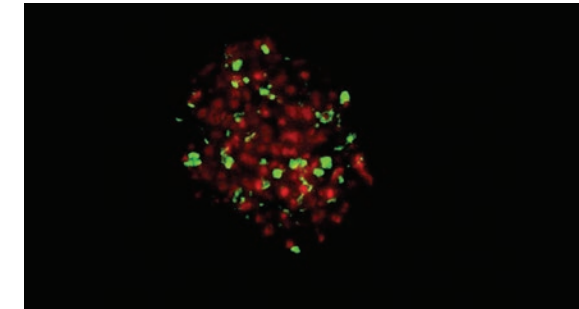
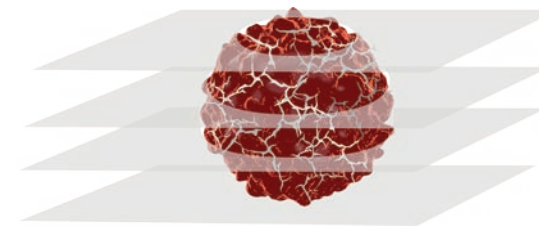

**Capture** → Three color z-stacked images are captured of tumoroids in each well over 120 hours.

**Process** → Each set of z-stacked images is z-projected at each time point for analysis of apoptosis (green fluorescence) or necrosis (red fluorescence).

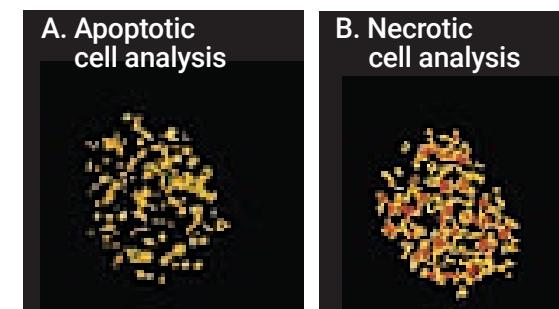

**Analyze** → Image analysis quantifies apoptosis (green fluorescence) and necrosis (red fluorescence).

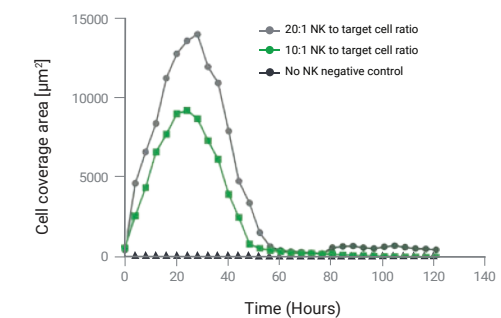

**Publish** → Apoptotic and necrotic induction are plotted over time for each condition.

# Select Applications

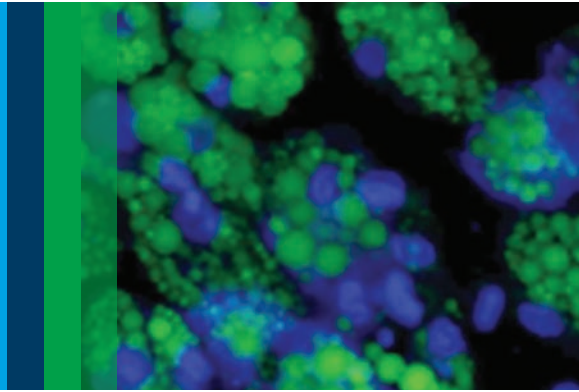

## 1. Phagocytosis assay

Macrophages are specialized cells that consume and digest foreign matter through phagocytosis. pH-sensitive bioparticles are a useful tool to study phagocytosis as particles fluorescence in response to the acidic environment of phagolysosomes. Cellular actin enables unique physical changes necessary for phagocytosis. This assay analyzed effects of actin disruption on bioparticle phagocytosis.

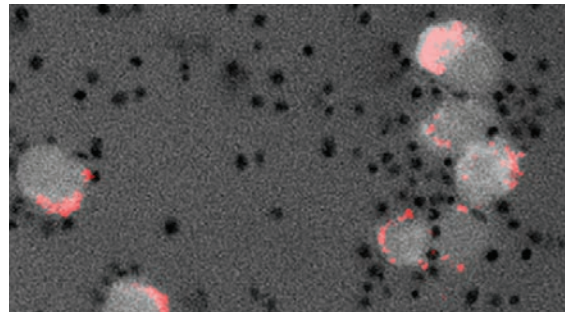

**Capture** → A two-channel image at one kinetic timepoint shows black extracellular bioparticles in contrast to the red fluorescence of phagocytized bioparticles (RFP).

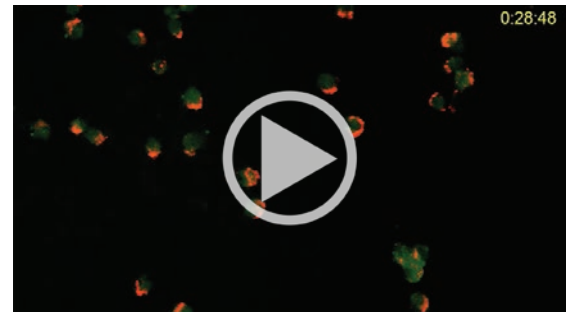

**Process** → A time-stamped movie is generated of kinetic images showing an increase in bioparticle phagocytosis over time (orange).

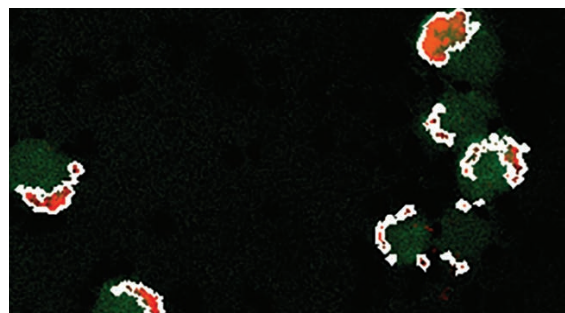

**Analyze** → A primary mask on bioparticle phagocytosis is applied to all kinetic images.

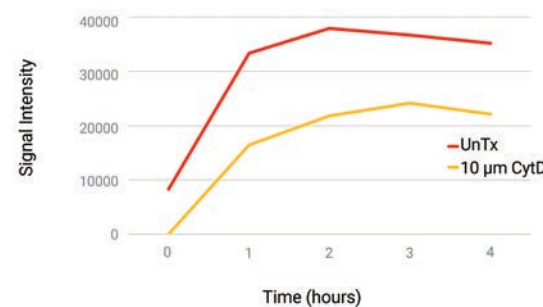

**Publish** → Compared to untreated macrophages (red) actin disruption causes decreased bioparticle phagocytosis (yellow).

# Select Applications

## 2. Autophagy (spot count)

Cells are treated with autophagy-inducing compounds. CYTO-ID dye in combination with automated object-based spot counting is used to quantitatively assess the effects of starvation and rapamycin on cellular autophagy by determining the size and number of autophagosomes per cell.

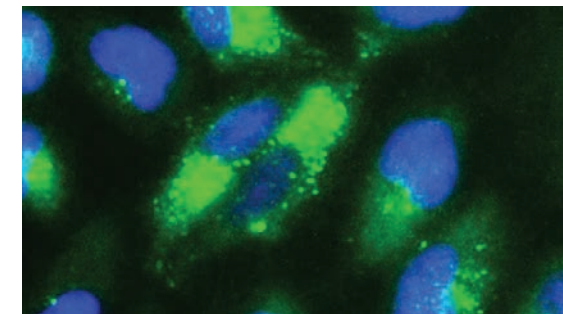

**Capture** → Each well is automatically imaged at 20x.

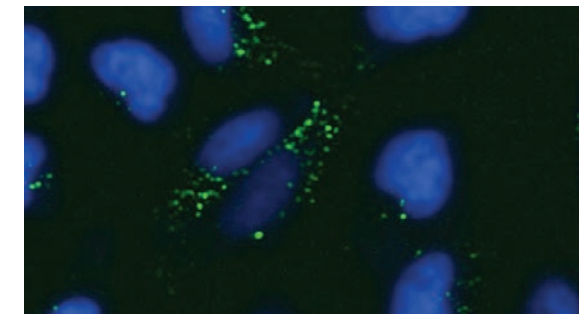

**Process** → Images are processed in order to better separate individual autophagosomes.

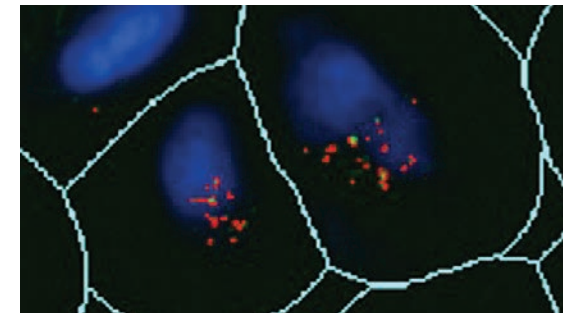

**Analyze** → The preprocessed image is analyzed, and each individual autophagosome is counted as a per-cell object.

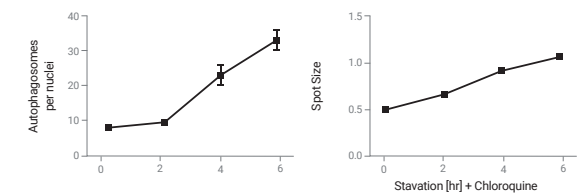

**Publish** → Consistent and precise measurement of spot count per cell (left) and spot size (right).

# Select Applications

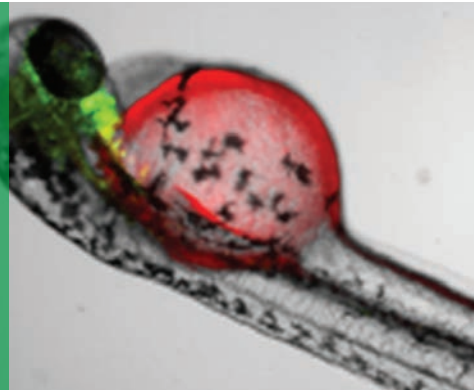

## 3. Calcium kinetics

Calcium is increasingly appreciated for its critical signaling role within the cell. Advanced microscopy methods are allowing us to visualize calcium release in real time. Cells are plated subconfluently and loaded with the calcium indicator dye, Fluo-4. Stimulation of calcium release by histamine causes an acute Fluo-4 response.

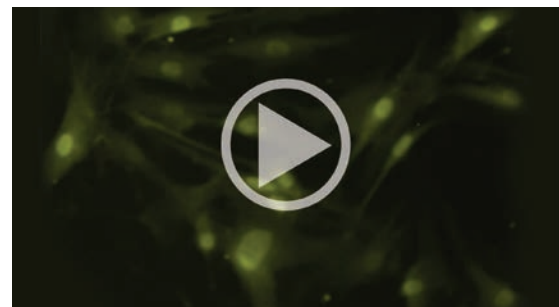
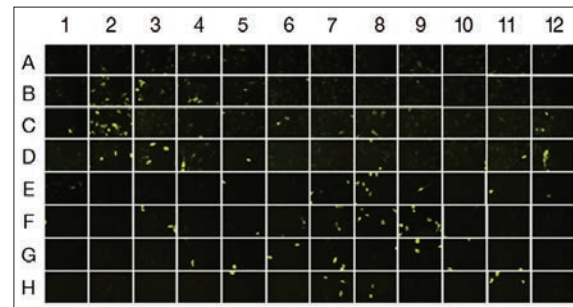

**Capture** → Kinetic images are captured every second for 2 minutes in each well of a 96-well plate.

**Process** → Time-stamped movies are generated from these images showcasing calcium release and recovery.

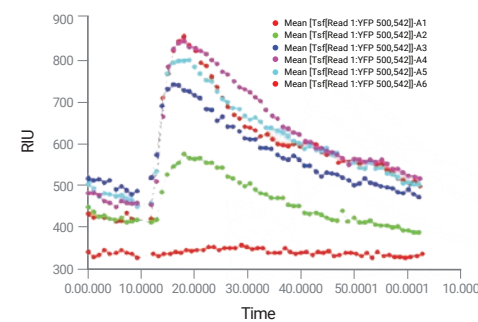
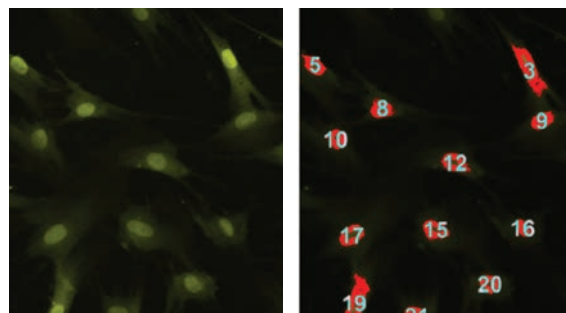

**Analyze** → Cell counts are performed at the time point of peak signal for data normalization.

**Publish** → Overlaid kinetic curves highlight the impact of experimental substrates on inhibition of calcium release.

# Select Applications

## 4. Measuring apoptosis in zebrafish treated with ethanol

Zebrafish embryos are treated with ethanol during the first 24 hours of development and the effects of ethanol treatment on cell death is assessed using acridine orange staining (green emission). Embryos were imaged in 9-well round bottom plates with a 2x objective as z-stacks in the bright field and GFP channels.

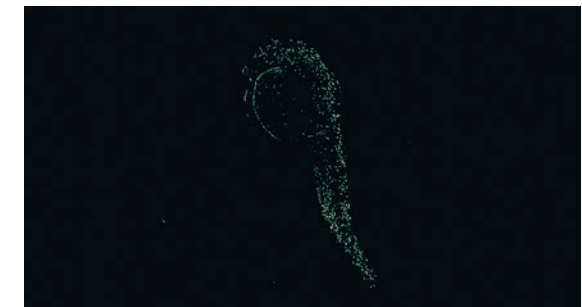
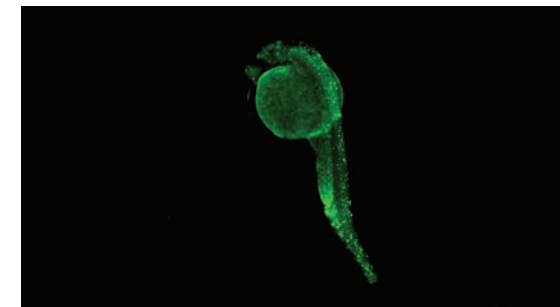

**Capture** → Each well is automatically imaged as a 2x z-stack.

**Process** → Images are z-projected then preprocessed in order to better separate individual positive cells.

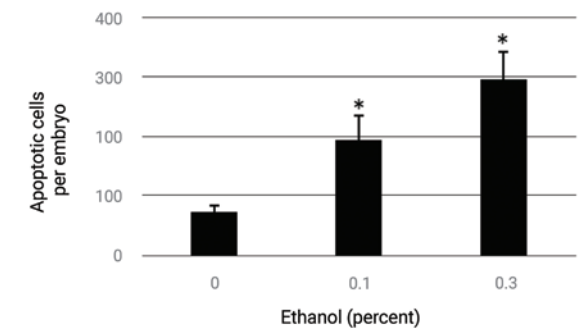
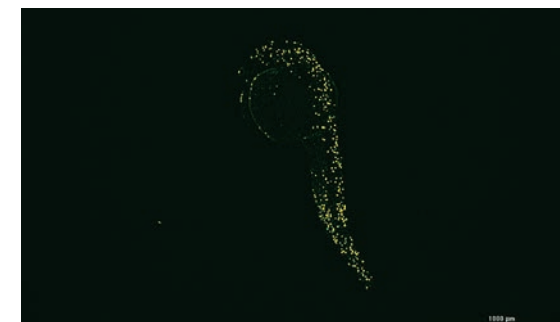

**Analyze** → The preprocessed images are analyzed, and each individual GFP positive cell is automatically identified and counted.

**Publish** → The effect of ethanol treatment on the number of apoptotic cells per embryo can be graphed for publication.

# Select Applications

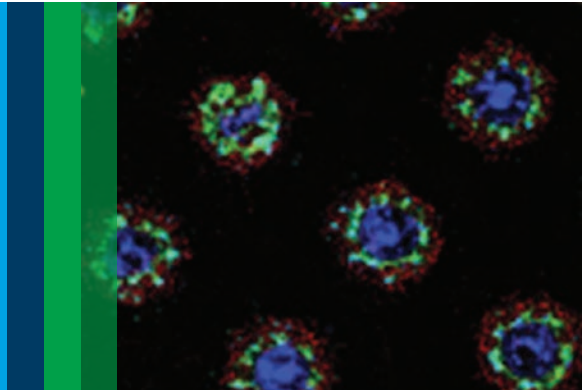

## 5. Quantifying poly-glutamine aggregates in *C. elegans* using vivoChip

*C. elegans* has emerged as a tool for whole organism based high-throughput screening as they model complex human diseases that cannot be easily reproduced in vitro. Here, we use a model of Huntington's disease which consists of poly-glutamine aggregation (PolyQ35:YFP). *C. elegans* were loaded onto the vivoChip (Newormics) and imaged in the YFP channel. Outlines of the worms were identified using Gen5, and the secondary mask function was used to count the aggregates per worm.

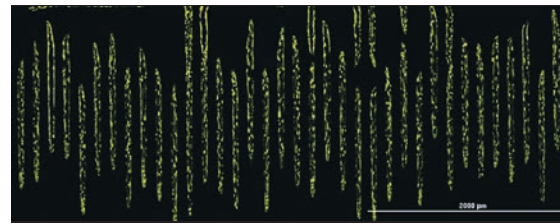
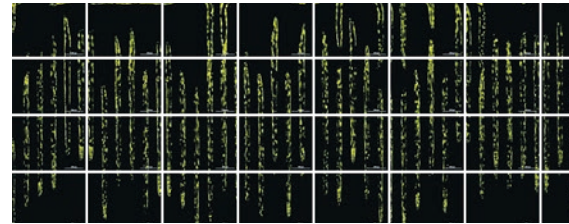

**Capture** → Each vivoChip is automatically imaged at 10x as a 4x8 montage and z-stack in brightfield and YFP channels.

**Process** → Image tiles are stitched together then z-projection and background subtraction are applied.

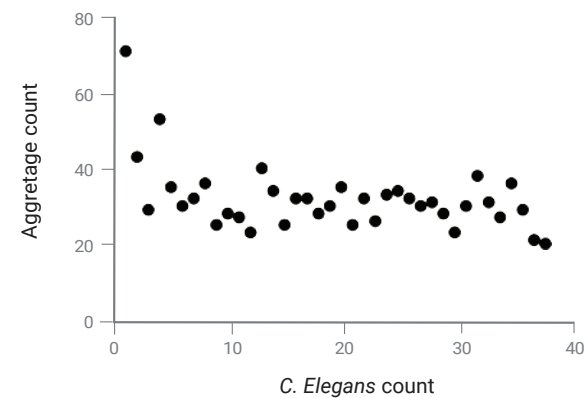
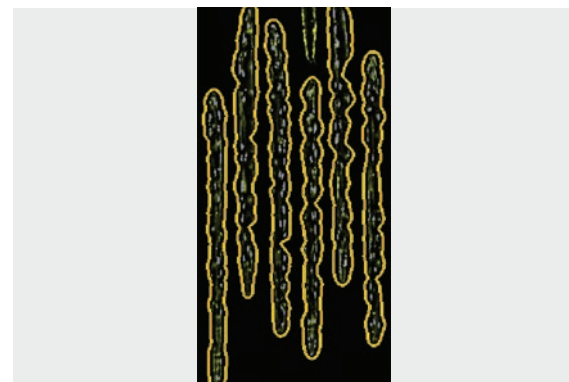

**Analyze** → The primary mask function in Gen5 identifies each individual worm and the secondary mask function identifies the polyQ aggregates per worm

**Publish** → Aggregate numbers can be quantified for publication.

# Select Applications

## 6. Cell cycle analysis using a nuclear stain

Cell cycle progression is a tightly-regulated process that involves the duplication of nuclear DNA content prior to cell division. A nuclear stain such as DAPI can be used to quantify this process since fluorescence intensity doubles as cells progress from G1 to G2 phase.

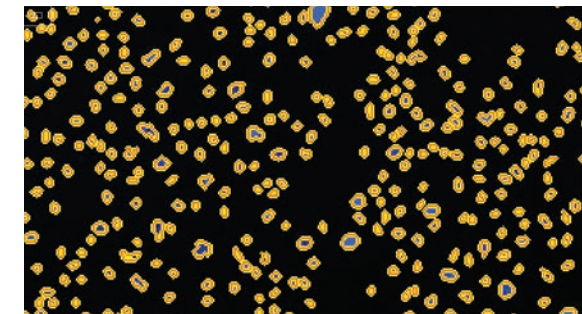
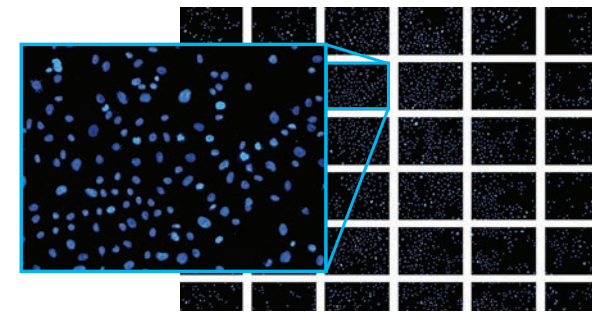

**Capture** → DAPI montage (6 x 6) image using 10x objective (one tile expanded).

**Process** → Stitched and background subtracted, montage image with cell nuclei identified (zoom shown, about 3,000 cells per well counted on final montage).

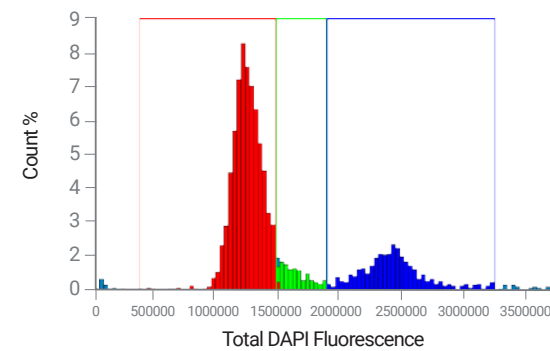

**Process** → Determination of G1, S, and G2 subpopulations using histogram analysis of object total DAPI fluorescence.

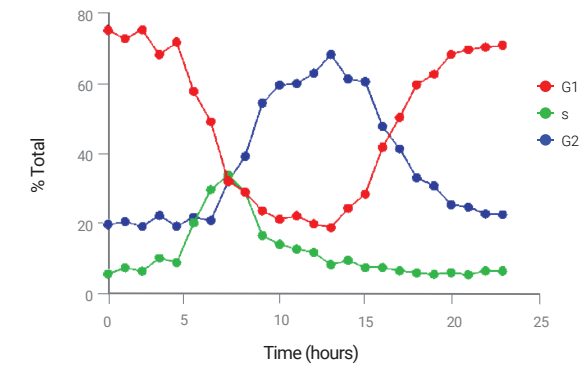

**Publish** → Cell cycle progression of synchronized PC-3 cells.

# Select Applications

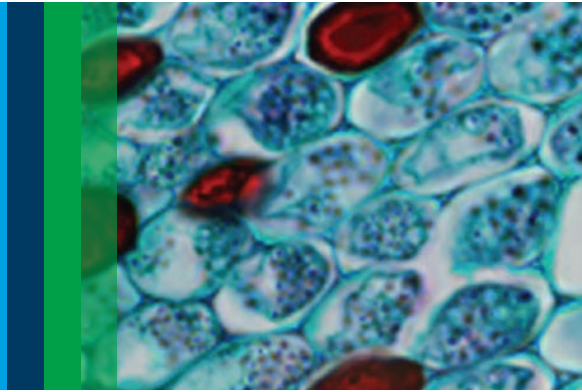

## 7. $\gamma$ H2AX foci spot counting as a determinant of genotoxicity

Double strand DNA breaks represent a critical form of genotoxic effect defined by histone 2AX (H2AX) phosphorylation to  $\gamma$ H2AX as part of the DNA repair process. Following immunostaining, automated fluorescent imaging and dual mask spot counting is performed to quantify labeled foci per nuclei after drug treatment.

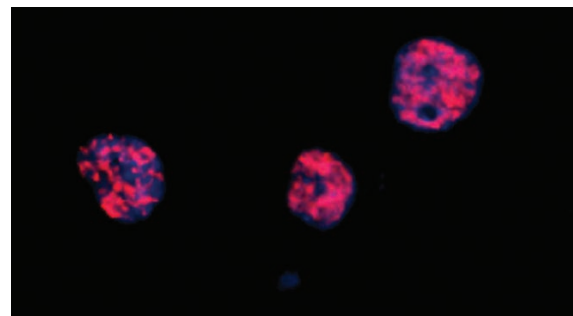

**Capture** → Images captured of DAPI stained nuclei and fluorescent antibody labeled  $\gamma$ H2AX signal.

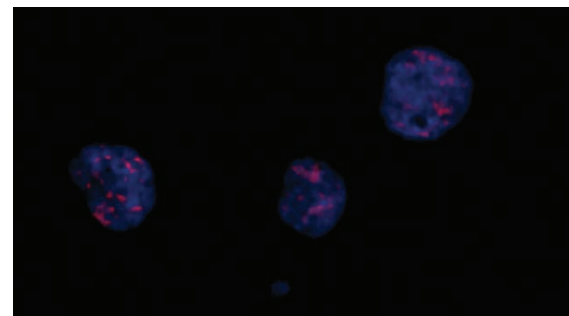

**Process** → Preprocessing eliminates background signal revealing actual labeled  $\gamma$ H2AX spots.

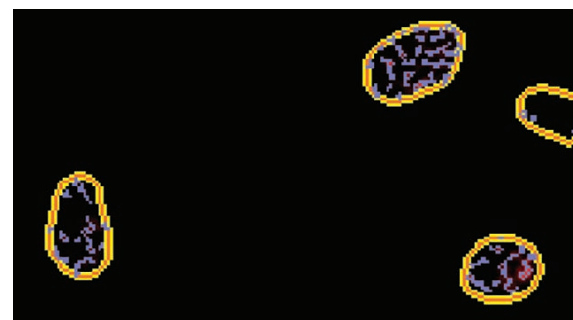

**Analyze** → Secondary spot counting capability allows quantification of spots per nuclei.

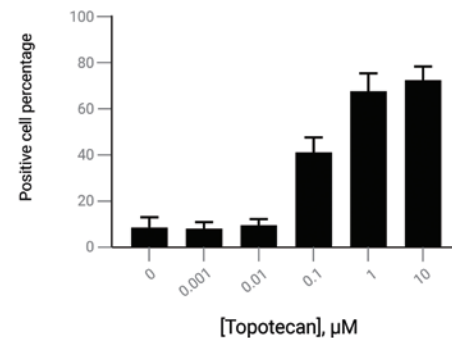

**Publish** → Statistical determination of minimum spots per nuclei enables calculation of induced DNA damage per treatment.

# Select Applications

## 8. High-throughput cell migration assay

Oris Pro is a cell migration assay conducted in a 384-well format. A biocompatible gel (BCG) is used to create a cell-free zone following media/cell addition. Image analysis of percent confluence is used to quantify the effect of migratory inhibitors.

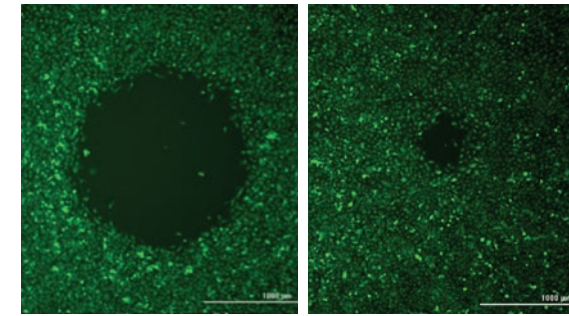

**Capture** → Cell migration into the detection zone is monitored kinetically.

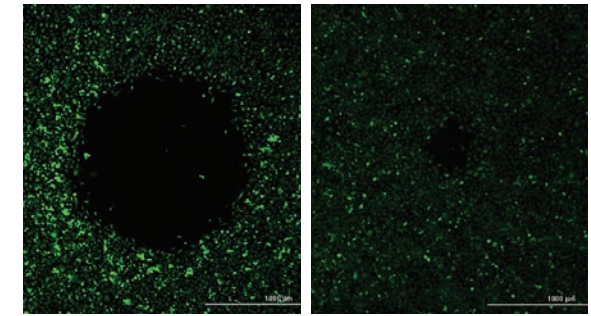

**Process** → Background flattening is applied to facilitate image analysis.

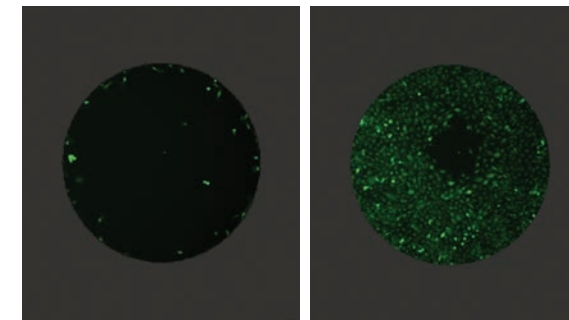

**Analyze** → A disc-shaped "plug" is applied to determine percent confluence within the cell-free zone.

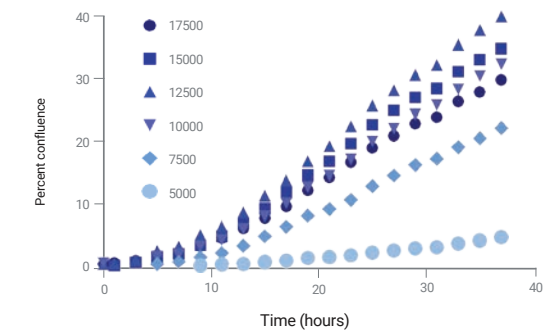

**Publish** → Kinetic and endpoint dose responses can quantify potency of migratory inhibitors.

# Select Applications

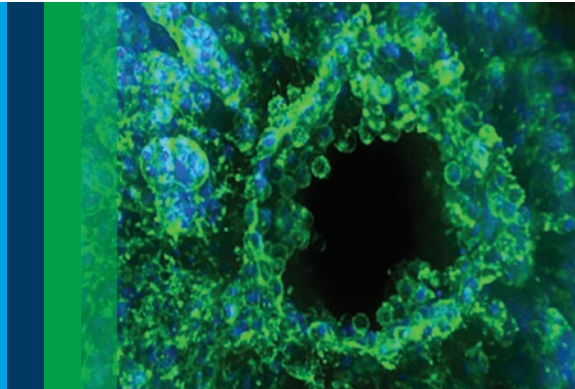

## 9. Label-free cell proliferation

Cells are seeded into 96-well microplates at 2000 cells per well. Environmental conditions, including temperature (37 °C), gas (5% CO<sub>2</sub>) and humidity (90%), are maintained during a five-day incubation by a BioSpa 8 automated incubator. Proliferation or drug-induced reduction in proliferation is detected by label-free cell counting using high-contrast brightfield.

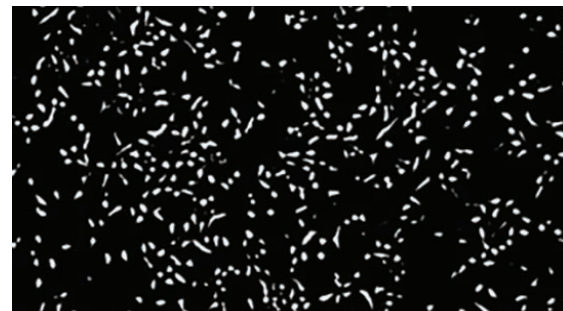
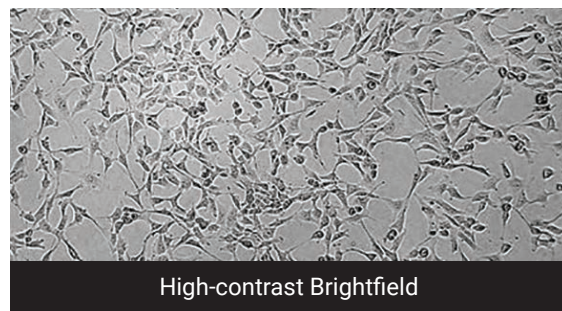

**Capture** → Each well is kinetically monitored every 2 hours using high contrast brightfield.

**Process** → All images are processed to maximize contrast of cells over background.

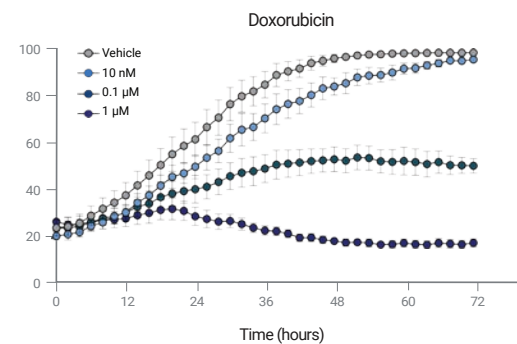

**Analyze** → The processed image is analyzed, cell objects are identified using intensity and size thresholds.

**Publish** → Antiproliferative agent pharmacology can be published.

# Select Applications

## 10. Gram stain imaging

Gram staining classifies bacterial strains based on differences in their cell wall. Green fluorescence results when CF 488A-Wheat Germ Agglutinin (WGA) binds to N-acetyl glucosamine in bacterial peptidoglycan. Gram positive bacteria appear bright green as they have a thick, exposed peptidoglycan layer. An outer membrane and thin peptidoglycan layer restrict the signal in gram negative bacteria.

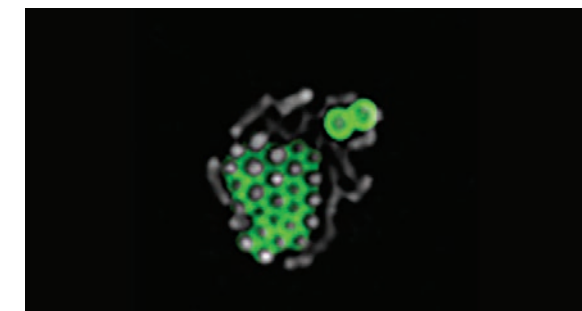
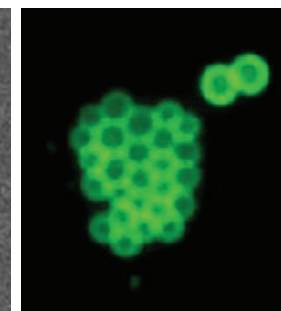
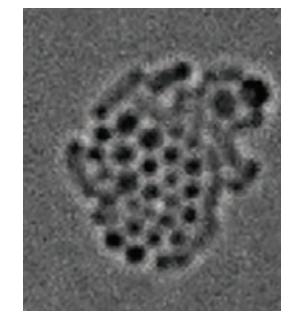

**Capture** → Raw image acquisition is done in brightfield and GFP using 60x oil immersion. A zoomed image of a mixed bacterial cluster is shown.

**Process** → Digital phase contrast (DPC) is applied to brightfield images using background flattening and smoothing.

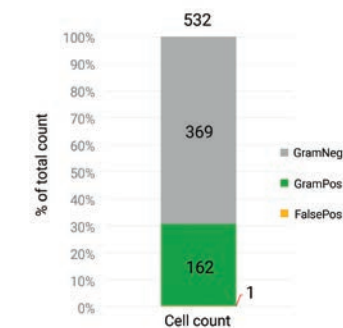
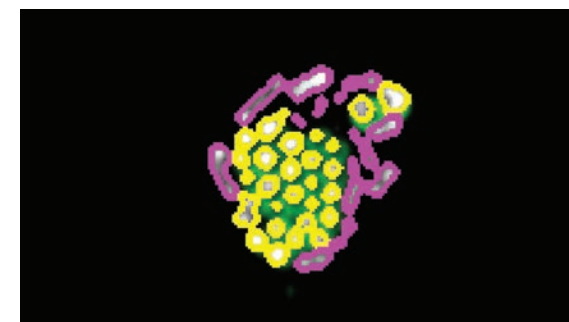

**Analyze** → Gram positive (yellow) and gram negative (pink) cells are distinguished using subpopulation criteria.

**Publish** → Imaging and analysis parameters applied to the CF 488A-WGA gram stain method resulted in 99.8% specificity for differentiating bacteria.

# Select Applications

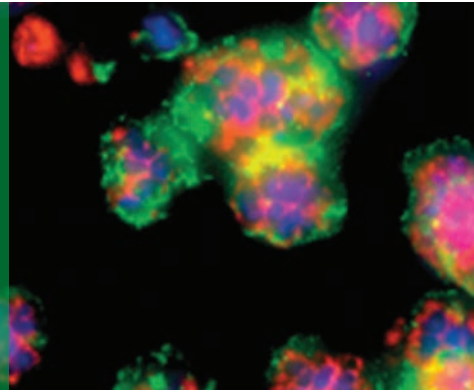

## 11. Quantifying cancer biomarker gene expression using RNA FISH

RNA fluorescence in situ hybridization (RNA FISH) is a common method to quantify gene expression, often used in cancer research. Highly specific probes and amplification systems allow image-based quantification of relative RNA expression, while counterstaining with a nuclear stain allows for normalization of expression to cell number.

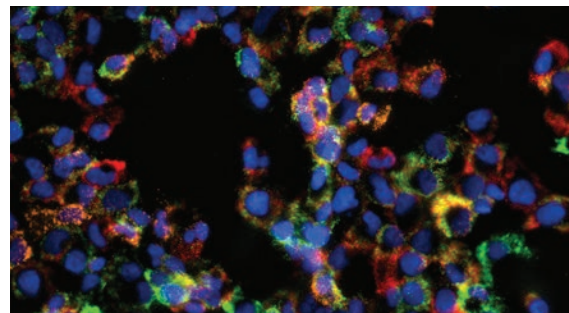

**Capture** → Images captured of DAPI stained nuclei in addition to hybridized, amplified, and fluorescently labeled RNA targets.

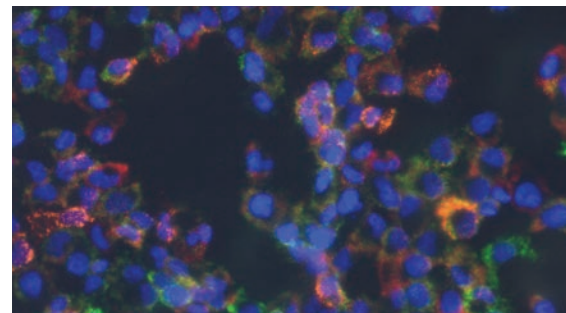

**Process** → Preprocessing eliminates background signal revealing actual signal from labeled RNA molecules.

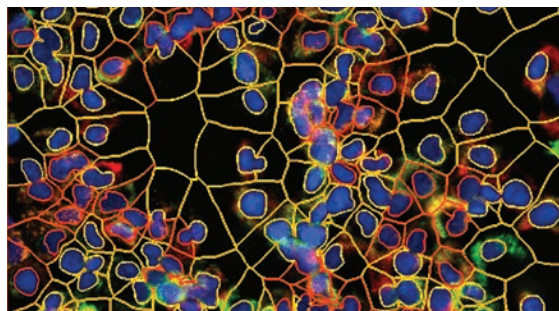

**Analyze** → Secondary masks quantify mean fluorescent signal from labeled targets. Subpopulation analysis identifies cells responding to treatment.

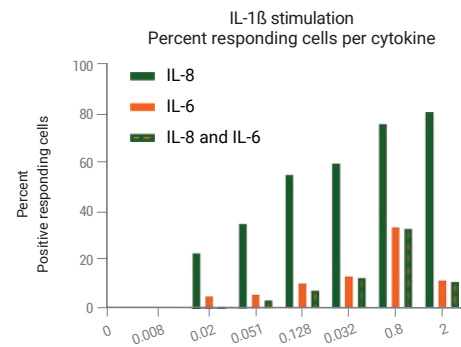

**Publish** → Normalization of responding cells to total cell count enables calculation of percent response via RNA expression per treatment.

# Select Applications

## 15. ELISpot imaging

The Cytation upright imaging module can be used to automate assays such as ELISpot, in which cell secretions are rendered visible through the use of a colorimetric reaction. Cytation fully automates image acquisition, processing, image analysis and object count.

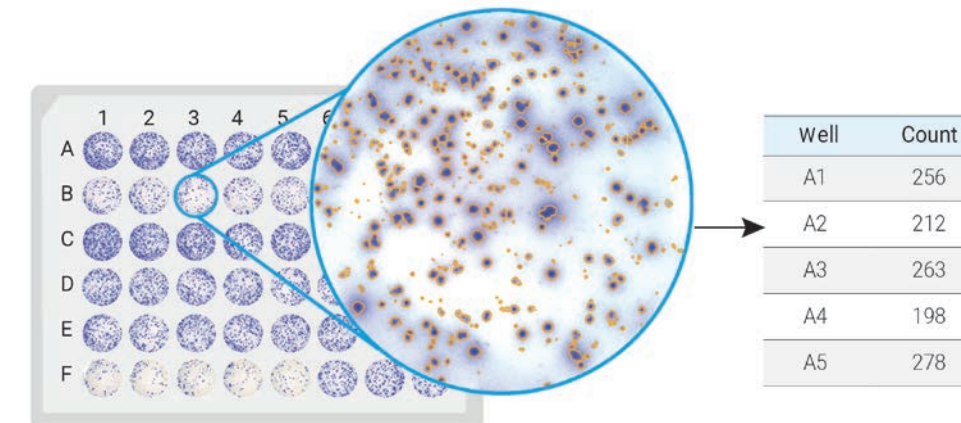

## 16. AutoROI identification feature

The AutoROI feature in Gen5 automates the identification of ROIs at low magnification, and then automatically images the ROIs at a higher magnification.

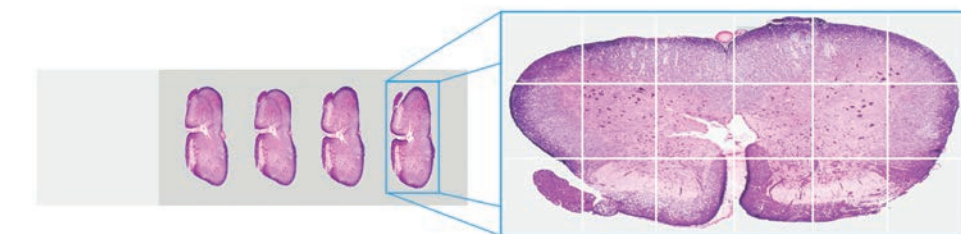

**A** Low-magnification scan and ROI identification

**B** High-magnification imaging



# Hardware Features, Automation, and Accessories



## Automation

For higher volume processing or long-term workflows, Cytation cell imaging multimode readers integrate to Agilent BioTek automation solutions.



### Agilent BioTek Cytation C10 integrated with BioStack

BioStack manages up to 50 microplates for automated imaging or multimode operations, including de-lidding and re-lidding of microplates used with cell-based assays.

# Hardware Features, Automation, and Accessories



### Agilent BioTek BioSpa 8 automated incubator

The BioSpa automated incubator has environmental controls and labware handling capabilities to facilitate long-term live-cell kinetic imaging processes, for up to eight microplates.



### Agilent BioTek Cytation Cell Count and Viability Starter Kit

The Agilent BioTek Cell Count and Viability Starter Kit includes everything a researcher needs to count cells and measure viability in a mammalian cell suspension using the BioTek Cytation 5 cell imaging multimode reader or Lionheart FX automated imager. Automates the process of mammalian cell counting to improve data quality and save time.

## Hardware Features, Automation, and Accessories



## Hardware Features, Automation, and Accessories



### Agilent BioTek AutoScratch wound making tool

The Agilent BioTek AutoScratch wound making tool automatically creates reproducible scratch wounds in cell monolayers grown in 24- or 96-well microplates for cell migration and invasion studies.

### CO<sub>2</sub>/O<sub>2</sub> control and reagent injectors



The compact gas controller maintains control of CO<sub>2</sub> and O<sub>2</sub> levels for live-cell assays. The gas controller is for use with Lionheart FX and Cytation systems.



The dual reagent injector module for Lionheart FX and Cytation allows fast cellular reactions to be imaged or detected.

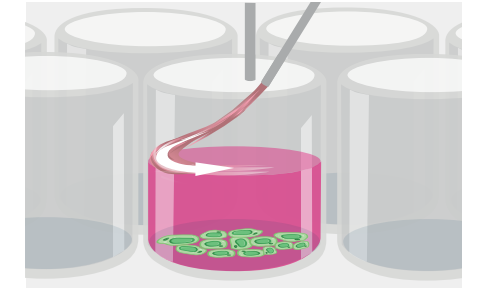

Angled injector tips protect cell monolayers from shear stress during injection.

### Confocal hardware

The Cytation C10 confocal microscope uses a Hamamatsu sCMOS camera, along with 60 μm and 40 μm Nipkow spinning disks. These components help ensure optimal resolution for spheroids and thick biologies.

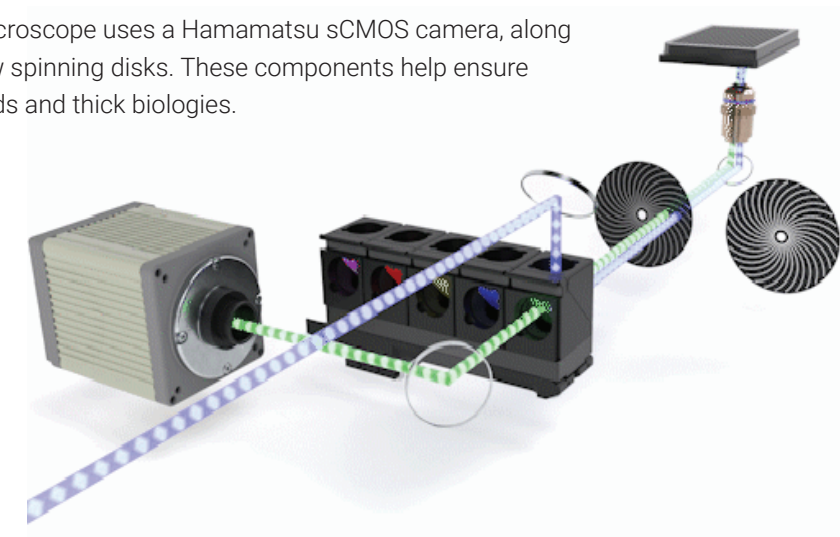

## Hardware Features, Automation, and Accessories



## Hardware Features, Automation, and Accessories



### High-quality objectives

Agilent BioTek uses high quality optical components, including objectives for standard and phase contrast imaging. Objective magnifications range from 1.25x to 100x oil immersion. 20x and greater objectives have correction collars to adjust for variations in sample vessel bottom thickness. Lionheart, Cytation C10, Cytation 7 and Cytation 5 have an automated 6-objective turret, Cytation 1 has an automated 2-objective turret.



### Labware adapters

From microscope slides, cell culture dishes and chamber slides to microplates, T75 flasks and hemocytometers, the BioTek range of labware adapters support many imaging workflows.

Gen5 software includes a database of predefined plate and other vessels. To quickly define a new microplates type, just take a photo with your phone and import the image to Gen5 for final definition – no need for cumbersome measurements.



### Imaging filter cubes

Using the 6-line laser light engine, the confocal cubes for Cytation C10 use deep blocking filters for optimum intensity and image resolution.

The filter/LED cubes used for widefield imaging use high-powered, low-maintenance LEDs to provide full control over light intensity and to reduce phototoxicity.

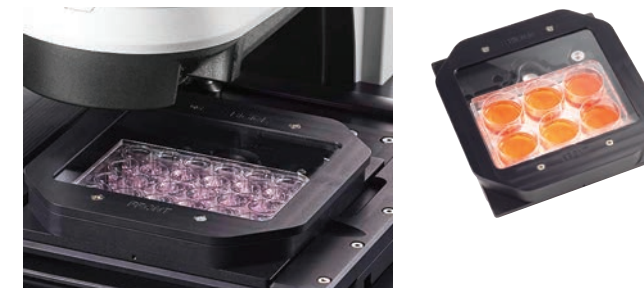

### Humidity control

The unique humidity chamber for Lionheart FX helps maintain cell viability during kinetic imaging sessions.

# Agilent BioTek Imaging and Microscopy

Agilent BioTek Imaging and Microscopy

## Instrument Comparison



Lionheart FX  
automated microscope



Lionheart LX  
automated microscope



Cytation C10  
confocal imaging reader



Cytation 7  
cell imaging multimode reader



Cytation 5  
cell imaging multimode reader



Cytation 1  
cell imaging multimode reader

	Lionheart FX	Lionheart LX	Cytation C10	Cytation 7	Cytation 5	Cytation 1
<b>General</b>						
Microplate types	6- to 1536-well plates					
Other labware	Slides, cell culture dishes and flasks, hemocytometers, chamber slides					
Incubation	to 40 °C		to 45 °C	to 45 °C	to 65 °C	to 45 °C
Joystick controller	•	•	•	•	•	
BioStack compatible			•	•	•	•
BioSpa compatible			•	•	•	•
Agilent BenchCel compatible				•	•	•
Multimode plate reading			•	•	•	•
<b>Imaging</b>						
Widefield fluorescence	•	•	•	•	•	•
Confocal fluorescence			•			
High-contrast brightfield	•	•	•	•	•	•
Brightfield	•		•	•	•	
Color brightfield	•	•	•	•	•	
Phase contrast	•		•		•	
Magnifications available - air	1.25x, 2.5x, 4x, 10x, 20x, 40x, 60x					
Magnifications available - oil	60x, 100x					
Inverted microscope	•	•	•	•	•	•
<b>Upright microscope</b>				•		

Learn more and buy online:

[www.agilent.com/lifesciences/biotek](http://www.agilent.com/lifesciences/biotek)

Get answers to your technical questions and  
access resources in the Agilent Community:

[community.agilent.com](http://community.agilent.com)

U.S. and Canada

**1-800-227-9770**

[agilent\\_inquiries@agilent.com](mailto:agilent_inquiries@agilent.com)

Europe

[info\\_agilent@agilent.com](mailto:info_agilent@agilent.com)

Asia Pacific

[inquiry\\_lsca@agilent.com](mailto:inquiry_lsca@agilent.com)

**For Research Use Only. Not for use in diagnostic procedures.**  
RA44460.1110532407

This information is subject to change without notice.

© Agilent Technologies, Inc. 2021  
Published in the USA, November 29, 2021  
5994-2410EN



---

Distributed by Fisher Scientific. Contact us today:

**In the United States**

Order online: [fishersci.com](http://fishersci.com)

Call customer service: 1-800-766-7000

**In Canada**

Order online: [fishersci.ca](http://fishersci.ca)

Call customer service: 1-800-234-7437

